

- Used with locknut to terminate steel or aluminum flexible metal conduit and armored cable to enclosure to form a 90° bend.
- Assembled with die cast locknut and tri-combo screws.
- Cast from high strength zinc alloy.



Part Number	Trade Size		
K-ASQ-037 §	3/8"		

§ 3/8" size fits 1/2" knockout

Certifications

UL File No. E155411, ASQ-037 also listed for use with 14-2 through 10-3 armored cable.
CSA File No. LR57925

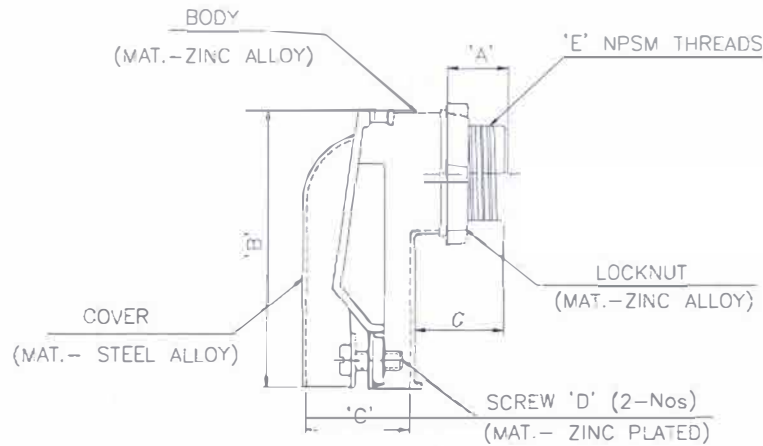

PRODUCT SPECIFICATION

DRG CRTL NO :



SR. No.	CAT. NO.	TRADE SIZE	'A' (WITHOUT INSULATOR)	'B'	'C'		'D' SCREW SIZE & LENGTH	'E' NPSM THREAD	'G'
					MIN.	MAX.			
1	K-ASQ-037	3/8"	0.38	1.63	0.42	0.76	No. 8 X 1/2"L	1/2"	0.54

NOTES :-

- 1) ALL DIMENSIONS ARE IN INCHES
- 2) CERTIFICATION/LISTING  & 
- 3) ASQ037
UL FILE NO. E155411, VOL.3, SECTION.1 & 18
UL FILE NO. E155411, VOL.4, SECTION.4
ABODY:- MAT.-3/8" to 1-1/4"-ZNC A-LOY
MAT.-1-1/2" to 2"-ALUMINIUM ALLOY
- 6) COVER:- STEEL ALLOY

04		-	-	SDM	PDL	URP	21-NOV-14
03		D2	-	RSP	PDL	LRP	24-MAY-14
02		-	-	SCK	DDV	AAS	11-APR-14
01	FORMAT UPDATED	-	-	ASP	PNN	URP	13-JAN-14
00	NEW RELEASED	-	-	PDS	PNN	URP	09-MAY-13
REV.	ALTERATION	ZONE	ECRN/PER NO.	DRN.	CHD.	APPD.	DATE
GENERAL TOLERANCE				PROCESS: DIE CASTING		PROJECTIONS	
±0.031				FINISH: NA			
				MATERIAL. SEE NOTE 5 & 6		SCALE : N.T.S	
				SHEET NO: 1 OF 1			
TITLE		90° ANGLE SQUEEZE CONNECTOR 3/8"-2"					
PATH							
DRG NO.		ASQ_CRD					

IF IN DOUBT, ASK

ALL DIMENSIONS ARE IN MM, UNLESS OTHERWISE SPECIFIED.