



Tel: (450) 449-0412 ; 1-866-540-0412 Fax: (450)449-9115 ; 1-866-499-9115



DX SERIES

3000 VA, PART # : DX 3000PHU

ELECTRICAL SPECIFICATIONS

PHASE:	1
FREQ.:	60 Hz.
INSUL. CLASS	H(180°C)
TEMP. RISE	< 115°C

PRIMARY VOLTAGE	
240/480	2, 2 1/2 % ANFC, 2, 2 1/2 % BNFC

SECONDARY VOLTAGE	
120/240	

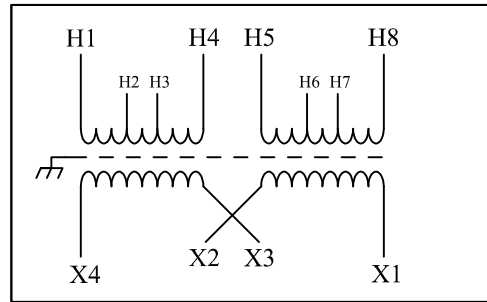

PRIMARY VOLTS	CONNECT PRIMARY LINES TO	INTER-CONNECT	CONNECT SECONDARY LINES TO
240	H1 - H7	H1 to H5 H3 to H7	
480	H1 - H7	H3 to H5	
SECONDARY VOLT			
120		X1 to X3 X2 to X4	X1 - X4
240		X2 to X3	X1 - X4

MECHANICAL SPECIFICATIONS: (Dimensions = inches).

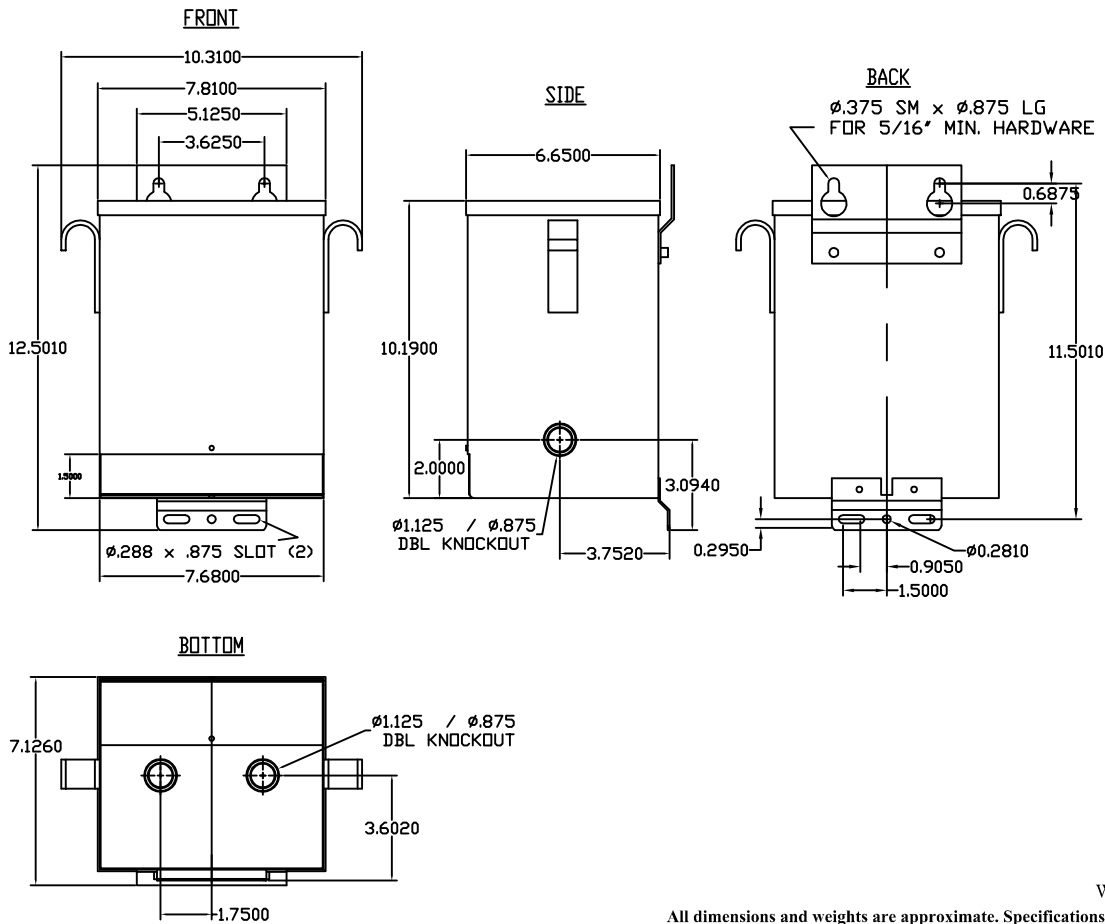

Weight : 24.9 Kg (55 lbs)
All dimensions and weights are approximate. Specifications may change without notice.

							MODEL NUMBER: DX 3000PHU		
ZONE	REV	REVISION	DESCRIPTION	DATE	APPROVAL	Drawn by:	SS	DWG NO. 71CUDX3000PHU-ENG	REV 00
DATE: JANUARY/24/2013								PAGE: 1 of 1	