



Tel: (450) 449-0412 ; 1-866-540-0412 Fax: (450)449-9115 ; 1-866-499-9115



DX SERIES

25000 VA, PART # : DX 25000QHU

ELECTRICAL SPECIFICATIONS

| | |
|--------------|----------|
| PHASE: | 1 |
| FREQ.: | 60 Hz. |
| INSUL. CLASS | H(180°C) |
| TEMP. RISE | < 115°C |

| PRIMARY VOLTAGE | |
|-----------------|------------------------------|
| 600 | 2, 2 ½ % ANFC, 2, 2 ½ % BNFC |

| SECONDARY VOLTAGE | |
|-------------------|--|
| 120/240 | |

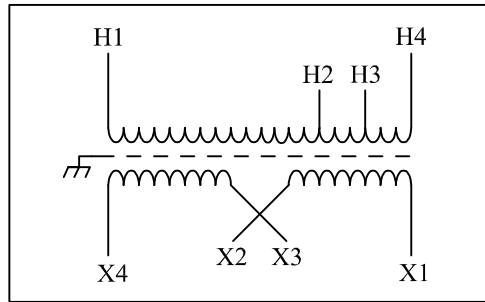

| PRIMARY VOLTS | CONNECT PRIMARY LINES TO | INTER-CONNECT | CONNECT SECONDARY LINES TO |
|----------------|--------------------------|----------------------|----------------------------|
| 600 | H1 - H4 | | |
| SECONDARY VOLT | | | |
| 120 | | X1 to X3 X2 to X4 | X1 - X4 |
| 240 | | X2 to X3 | X1 - X4 |

MECHANICAL SPECIFICATIONS: (Dimensions = inches).

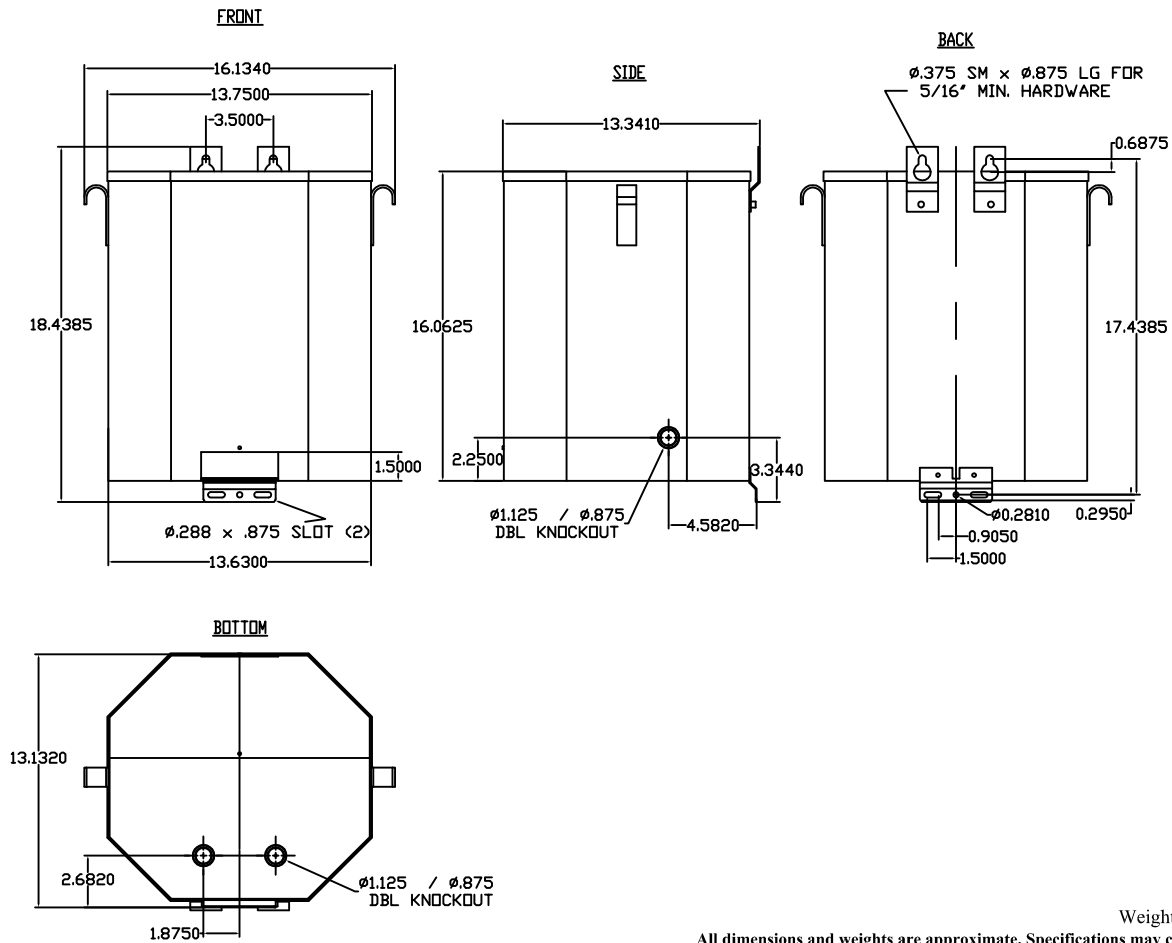

Weight : 113 Kg (250 lbs)
All dimensions and weights are approximate. Specifications may change without notice.

| | | | | | | | | | | |
|-----------------------|-----|----------|-------------|------|---------------------------------------|--------------|------------|---------|-------------------------------------|-----------|
| | | | | | TRANSFAB magnetic solutions | | TMS | | MODEL NUMBER: DX 25000QHU | |
| ZONE | REV | REVISION | DESCRIPTION | DATE | APPROVAL | Drawn by: | SS | DWG NO. | 71CUDX25000QHU-ENG | REV 00 |
| DATE: JANUARY/24/2013 | | | | | | PAGE: 1 of 1 | | | | |