



Tel: (450) 449-0412 ; 1-866-540-0412 Fax: (450)449-9115 ; 1-866-499-9115



# DX SERIES

## 15000 VA, # : DX 15000PHU

### ELECTRICAL SPECIFICATIONS

PHASE:	1
FREQ.:	60 Hz.
INSUL. CLASS	H(180°C)
TEMP. RISE	< 115°C

PRIMARY VOLTAGE	
240/480	2, 2 1/2 % ANFC, 2, 2 1/2 % BNFC

SECONDARY VOLTAGE
120/240

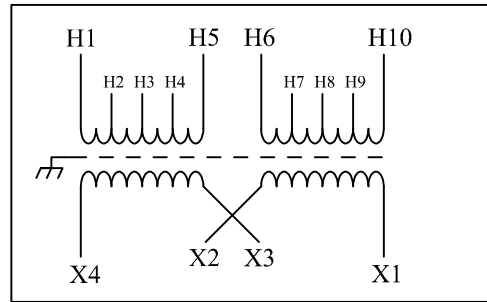

PRIMARY VOLTS	CONNECT PRIMARY LINES TO	INTER-CONNECT	CONNECT SECONDARY LINES TO
240	H1 - H10	H1 to H7 H10 to H4	
480	H1 - H10	H4 to H7	
SECONDARY VOLT			
120		X1 to X3 X2 to X4	X1 - X4
240		X2 to X3	X1 - X4

### MECHANICAL SPECIFICATIONS: ( Dimensions = inches).

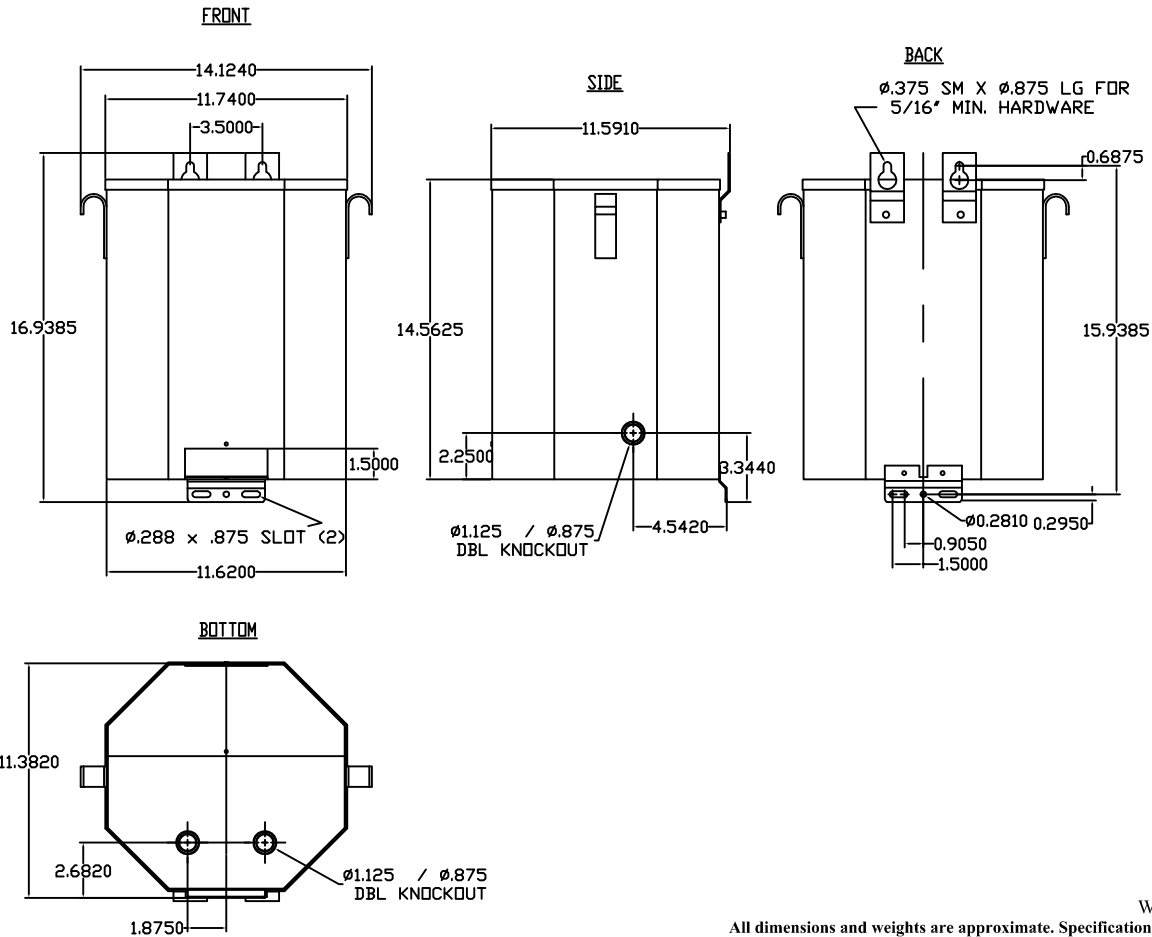

Weight : 77.1 Kg ( 170 lbs )  
All dimensions and weights are approximate. Specifications may change without notice.

							MODEL NUMBER: <b>DX 15000PHU</b>		
ZONE	REV	REVISION	DESCRIPTION	DATE	APPROVAL	Drawn by:	SS	DWG NO. 71CUDX15000PHU-ENG	REV 00
DATE: JANUARY/24/2013								PAGE: 1 of 1	