

POLYAMIDE SCREW CLAMP TERMINAL BLOCKS

ELECDIRECT.COM POLYAMIDE SCREW CLAMP TERMINAL BLOCKS

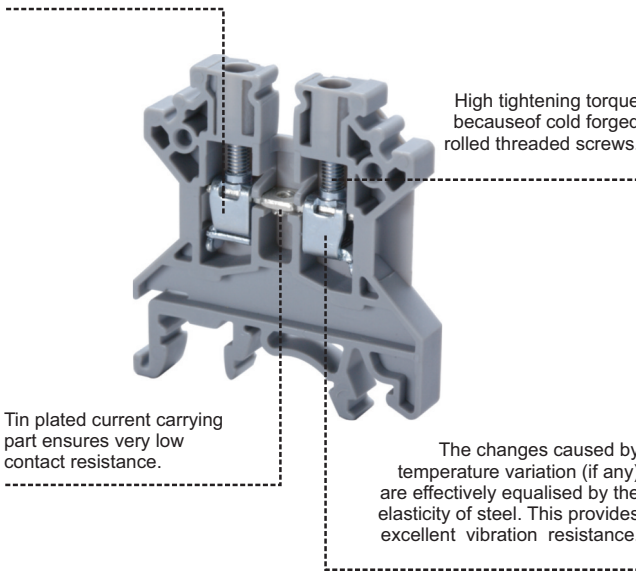

Can accommodate two conductors of the same size per clamping unit.



High tightening torque because of cold forged rolled threaded screws.

Tin plated current carrying part ensures very low contact resistance.

The changes caused by temperature variation (if any) are effectively equalised by the elasticity of steel. This provides excellent vibration resistance.

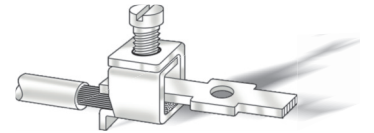

The Connection:

elecDirect.com's Screw Clamp Terminal Blocks provide maximum wiring efficiency and reliability. These Terminal Blocks provide a vibration-proof connection and the clamps do not need to be re-tightened. All the parts in the Terminal Block are captive. They have high contact force and are absolutely gas tight, thus providing a reliable electrical and mechanical connection.

PRODUCT RANGE OVERVIEW

	Rated Cross Section (mm ²)										
Functionality	1.5	2.5	4	6	10	16	25	35	50	95	
Feed Through Terminal Blocks											
2 wire Terminal Blocks		●	●	●	●	●	●	●	●	●	
3 and 4 wire Terminal Blocks			●								
Ground (Earth) Terminal Blocks			●	●	●	●		●			
Clamps for Neutral Connection				●		●		●			
Double Level Terminal Blocks			●								
Triple Level Terminal Blocks		●									
Distribution Blocks			●	●	●	●	●	●			
Fuse Terminal Blocks			●	●							
Disconnect & Test Terminal Blocks	●		●	●							
Thermocouple Terminal Blocks		●									
Active Terminal Blocks			●								
Micro Terminal Blocks	●		●								
Panel Mount Terminal Blocks			●								
Spring Loaded Terminal Blocks			●	●	●						
High Voltage Terminal Blocks			●	●	●						
Tab Connection Terminal Block			●								





SCREW CLAMP TERMINAL BLOCKS





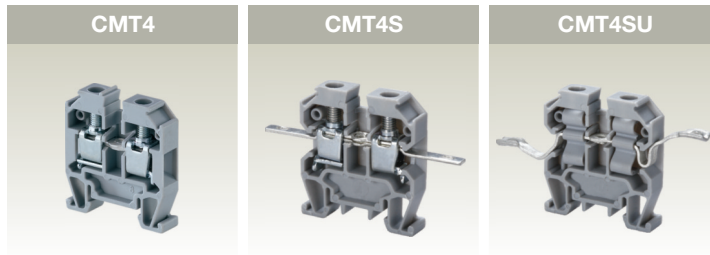



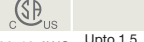
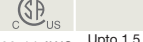



MICRO TERMINAL BLOCKS

These Terminal Blocks are extremely compact and are used in applications with space constraints. These blocks should be used with DIN 15 type (DIN 2) rails.

The terminals marked with  can be used in potentially explosive atmosphere. For detailed information refer page E-44.



	CMT4	CMT4S	CMT4SU
Terminal Block Pitch	6 mm	6 mm	6 mm
Height x Width	29 x 27 mm	29 x 46 mm	29 x 35.5 mm
Connection Possibility	Stranded Wire 0.5 to 4 sq.mm Solid Wire 0.5 to 6 sq.mm	0.5 to 4 sq.mm 0.5 to 4 sq.mm	Upto 1.5 sq.mm
Stripping Length	9 mm	9 mm	9 mm
Insulation Material / Comparative Tracking Index	Polyamide 66 / I	Polyamide 66 / I	Polyamide 66 / I
Type of Connection	 2 screw clamps and 1 tapped hole for cross connection	2 screw clamps, 2 solder points and 1 tapped hole for cross connection	2 uneven level solder points and 1 tapped hole for cross connection
Approvals			
Rated Connecting Capacity	22-10 AWG 0.5-4 sq.mm 22-10 AWG	Upto 1.5 sq.mm 22-12 AWG	22-14 AWG Upto 1.5 sq.mm 22-14 AWG
Voltage Rating	300 V	300 V	300 V
Rated Impulse Voltage/Pollution Degree	400 V 4 KV / 3	160 V 1.5 KV / 3	160 V 1.5 KV / 3
Current Rating	35 A 32 A	35 A 25 A	300 V 15 A 15 A
Torque	7 lb-in 0.5 Nm	6 lb-in 0.5 Nm	7 lb-in

Other Approvals						
	Type Cat. No.	Std. Packing in Pcs.	Type Cat. No.	Std. Packing in Pcs.	Type Cat. No.	Std. Packing in Pcs.
Terminal Block	CMT4	100	CMT4S	100	CMT4SU	100
End Plate 	EPCMT4	50	EPCMT4	50	EPCMT4	50
Partition Plate 	PPCMT4	50	PPCMT4	50	PPCMT4	50
Separator Plate 						
End Clamp 	CA602	50	CA602	50	CA602	50
Pre Assembled Shorting Links	2 way CA727/2 3 way CA727/3 4 way CA727/4 10 way CA727/10	100 100 100 10	CA727/2 CA727/3 CA727/4 CA727/10	100 100 100 10	CA727/2 CA727/3 CA727/4 CA727/10	100 100 100 10
Insulated Assembled Shorting Links	2 way CA747/2 3 way CA747/3 4 way CA747/4 10 way CA747/10	100 100 100 10	CA747/2 CA747/3 CA747/4 CA747/10	100 100 100 10	CA747/2 CA747/3 CA747/4 CA747/10	100 100 100 10
Permanent Shorting Link	2 way CA703/1 3 way CA704/1 4 way CA705/1 10 way CA732/10 10 way (breakable) CA732/10-A 100 Way CA732/100	100 100 100 100 100 10	CA703/1 CA704/1 CA705/1 CA732/10 CA732/10-A CA732/100	100 100 100 100 100 10	CA703/1 CA704/1 CA705/1 CA732/10 CA732/10-A CA732/100	100 100 100 100 100 10
Short Sleeve & Screw for Quick Permanent Shorting 	CA607/S/Q	100	CA607/S/Q	100	CA607/S/Q	100
Removable Shorting Links 	CA706/1	100	CA706/1	100	CA706/1	100
Long Sleeve & Screw for Temporary Shorting 	CA607/L/Q	100	CA607/L/Q	100	CA607/L/Q	100
Insulated Comb Type Shorting Link	2 way CA714/2 3 way CA714/3 4 way CA714/4 10 way CA714/10	100 100 100 20	CA714/2 CA714/3 CA714/4 CA714/10	100 100 100 20	CA714/2 CA714/3 CA714/4 CA714/10	100 100 100 20
Test Socket 	CA707/TS/03	100	CA707/TS/03	100	CA707/TS/03	100
Marking Tags (K Type) 	MT2	100	MT2	100	MT2	100

* Add required voltage to part number as a suffix, i.e. CSFL4U(L)/24 for 24V DC

TERMINAL BLOCK TECHNICAL INFORMATION

ATEX APPROVED TERMINAL BLOCKS

The ATEX approved Terminal Blocks have been assured for compliance with :

- EN 50014
- EN 60079-7
- EN 50020
- EN 50281-1-1-1

Certification can be traced to Techspan Certificate Number TÜV 06 ATEX 2968U

Technical Data:

Operating Temperature -40°C to +85°C

Maximum Voltage for intrinsically safe "i" circuits * 60 V

Type No.	Rated Voltage			Rated Current	Wire Range
	for DIN 35 Rail	for DIN 32 Rail	for DIN 15 Rail		
CTS2.5UN	630 V	630 V		21 A	0.5-2.5 sq.mm
CTS4UN	630 V	630 V		28 A	0.5-4 sq.mm
CTS6U	630 V	630 V		36 A	1.5-6 sq.mm
CTS10U	630 V	630 V		50 A	1.5-10 sq.mm
CTS16U	630 V	500 V		66 A	2.5-16 sq.mm
CTS25U	630 V	630 V		88 A	6-25 sq.mm
CTS35U	630 V	630 V		109 A	10-35 sq.mm
CMC1-2	400 V	320 V		28 A	0.5-4 sq.mm
CMC2-2	500 V	500 V		28 A	0.5-4 sq.mm
CDL4U	320 V	320 V		28 A	0.5-4 sq.mm
ODL4U	630 V	500 V		28 A	0.5-4 sq.mm
CTL2.5U	320 V	320 V		21 A	0.5-2.5 sq.mm
CTL2.5UH	320 V	320 V		21 A	0.5-2.5 sq.mm
CMT4			320 V	28 A	0.5-4 sq.mm
CSC2.5T	500 V			21 A	0.5-2.5 sq.mm
CSC4T	500 V			28 A	0.5-4 sq.mm
CSC6T	500 V			36 A	0.5-6 sq.mm
CSC2.5T1-2	500 V			21 A	0.5-2.5 sq.mm
CSC2.5T2-2	500 V			21 A	0.5-2.5 sq.mm
CSC4T1-2	500 V			28 A	0.5-4 sq.mm
CSC4T2-2	500 V			28 A	0.5-4 sq.mm
CGT4U	PE	PE			0.5-4 sq.mm
CGT4N	PE				0.5-4 sq.mm
CGT10U	PE	PE			1.5-10 sq.mm
CGT35U	PE	PE			10-35 sq.mm
CGMT4			PE		0.5-4 sq.mm
CMB4		320 V (Panel Mount)		28 A	0.5-4 sq.mm
CSCP2.5T		500 V (Panel Mount)		21 A	0.5-2.5 sq.mm
CSCP2.5T2		500 V (Panel Mount)		21 A	0.5-2.5 sq.mm

* CGT Series (Earthing) Terminal Blocks can not be used in "i" intrinsically safe circuit

Note:

For installation instructions refer to www.elecDirect.com

TERMINAL BLOCK TECHNICAL INFORMATION

WIRE TIGHTENING

The design of the elecDirect.com Screw Clamps / Cable Lug system ensures vibration proof positive connection wires at the recommended torque values. However, elecDirect.com Terminal Blocks can withstand torque levels in excess of the recommended torque values. The Terminal Block clamping parts when tightened within the torque range ensure optimum performance as given below:

- ▣ The voltage drop (contact resistance) is well below the specified limits
- ▣ The wire gets clamped perfectly to form a gas tight connection
- ▣ The clamping yoke does not get damaged mechanically. The tightening torque according to IEC 60947-7-1 table 4, is the safe limit of the torque which guarantees the successful clamping of the connected wire.

elecDirect.com Terminal Blocks tightening torque data is given in the respective product pages.

All elecDirect.com Terminal Blocks are designed to function with rated wire sizes as per their respective AWG (American Wire Gauge) or Metric size/system. The Terminal Blocks are tested for Gauge Insertion as per VDE 0660.

Tightening Torque for Screw Clamp Terminal Blocks

Terminal Blocks	Thread Size of Fastener	Recommended Torque Value
CTS2.5UN/CPT(M)/CPT5	M 2.5	0.4 Nm
CTS2.5(M)/CMST1/CMST2	M 2.6	0.4 Nm
CTS2.5/CMT4/CMB4/CDL4U/ODL4U/ CGT4U/CTS4UN/CTS4SC/CSTSB3/CSFL4U/ CSDL4U/CKT4U/CPT7.5/DDFL4U/ DDFL4U(E)/DDFL4U(E)LR/CMC1-2/CMC2-2	M 3	0.5 Nm
CTS6/CTS6SC/CTS6U/CSFL6U/CENC4	M 3.5	0.8 Nm
CTS10/10U/CTS16/16U/CSTSN4/B4/CDTTS/ CTS10SC/CGT10U/DDPT/CDTTU/CSTSN4U/STH4	M 4	1.2 Nm
CTS25U/CSTSB5/N5/N5(15)/RN5/N5U/CENC16	M 5	2.0 Nm
CTS35/CTS35U/CENC35/CGT35U/CSTSN6U	M 6.0	2.0 Nm
CTS35L/35LS/CSTSRN6/CSTSN6	M 6.0	2.8 Nm
CTS70L/70LS/CTS95L/95LS	M10.0	10.0 Nm

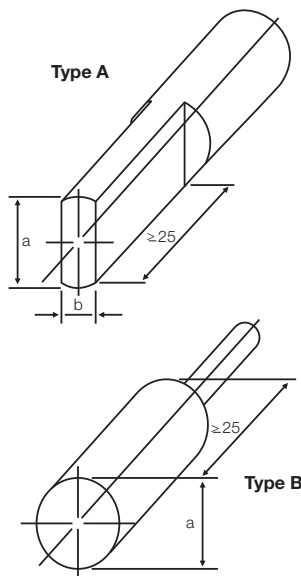

Representative Picture of Gauge Type A and Type B

Conductor cross-sections and Gauges

Conductor Cross-section							
Flexible (sq.mm)	Rigid (solid or stranded) (sq.mm)	Gauge Type A			Gauge Type B		Permissible deviation for a and b
		Marking	Diameter a (mm)	Width b (mm)	Marking	Diameter a (mm)	
1.5	1.5	A1	2.4	1.5	B1	1.9	0 / -0.05
2.5	2.5	A2	2.8	2.0	B2	2.4	0 / -0.05
2.5	4	A3	2.8	2.4	B3	2.7	0 / -0.05
4	6	A4	3.6	3.1	B4	3.5	0 / -0.06
6	10	A5	4.3	4.0	B5	4.4	0 / -0.06
10	16	A6	5.4	5.1	B6	5.3	0 / -0.06
16	25	A7	7.1	6.3	B7	6.9	0 / -0.07
25	35	A8	8.3	7.8	B8	8.2	0 / -0.07
35	50	A9	10.2	9.2	B9	10.0	0 / -0.07
50	70	A10	12.3	11.0	B10	12.0	0 / -0.08
70	95	A11	14.2	13.1	B11	14.0	0 / -0.08
95	120	A12	16.2	15.1	B12	16.0	0 / -0.08
120	150	A13	18.2	17.0	B13	18.0	0 / -0.08
150	185	A14	20.2	19.0	B14	20.0	0 / -0.08
185	240	A15	22.2	21.0	B15	22.0	0 / -0.09
240	300	A16	26.5	24.0	B16	26.0	0 / -0.09



TERMINAL BLOCK TECHNICAL INFORMATION

ELECTRICAL DATA

elecDirect.com Terminal Blocks are standard blocks for industries such as Switchgear, Distribution, Machine Tools Control, Instrumentation Installations, Material Handling Equipments, Process Plants On and Offshore Installations and Panel Board Construction.

Rated Voltage

The voltage rating of the product is assigned in accordance with specifications related to Creepage & Clearance distance defined in respective **EN, VDE, UL** and **CSA** standards, for the environmental conditions and pollution degrees as given below.

Degree of Pollution

Pollution degree 1

No pollution or only dry, non-conductive pollution occurs. The pollution has no influence.

Pollution degree 2

Only non-conductive pollution occurs except that occasionally a temporary conductivity caused by condensation is to be expected.

Pollution degree 3

Conductive pollution occurs or dry, non conductive pollution occurs which becomes conductive due to condensation is to be expected.

Pollution degree 4

The pollution generates persistent conductivity caused by conductive dust or by rain or snow.

Rated Impulse Voltage

The rated impulse voltage of the product is the peak value of an impulse voltage with which the terminal block can be loaded and on which the creepage and clearances according to relevant standard are based.

CTI - Comparative Tracking Index of Insulation material

The insulation material is divided into four groups according to their CTI (Comparative Tracking Index)

Insulation I	600 ≤ CTI
Insulation II	400 ≤ CTI < 600
Insulation III a	175 ≤ CTI < 400
Insulation III b	100 ≤ CTI < 175

The Comparative Tracking Index must be defined according to **DIN IEC 112/ VDE 0303 part 1** on specimens made specifically for this purpose with test solution A. The proof-tracking index (PTI) is also used to identify the tracking characteristics of materials. A material may be included in one of the four groups given above on the basis that its PTI, established by the method of IEC 112 using solution A, is equal to or greater than the lower value specified for the Insulation group.

Current carrying capacity of terminal block (DIN EN 60947-7-1/VDE 0611part1: 2000-05)

The data given below is for unprepared conductor ends without ferrules. The rated current for Terminal Blocks with specific functions such as Fuse type, Relays, Terminal Blocks incorporating electronic components is to be specified by manufacturer.

Rated Cross Section (sq.mm)	0.2	0.5	0.75	1	1.5	2.5	4	6	10	16	25	35	50	70	95	120	150	185	240	300
Test current (A)	4	6	9	13.5	17.5	24	32	41	57	76	101	125	150	192	232	269	309	353	415	520

Current Rating with two wire/conductors

The total current of the two wires / conductors should not exceed the continuous current rating of the Terminal Block. The continuous current rating is the maximum current the terminal block can conduct without a temperature rise of 45 K (as per EN standard) and 300C (as per UL / CSA standard).

Note

For PE-Terminals only one conductor should be connected per clamping part, in accordance with installation requirement.

TERMINAL BLOCK TECHNICAL INFORMATION

TERMINAL BLOCK MATERIAL

Polyamide 6.6

Engineering Thermoplastic Polyamide 6.6 has excellent electrical, mechanical and chemical characteristics, even at temperature as high as 105°C. This insulating material has high mechanical strength - it is unbreakable. Its resistance to tracking is similar to Melamine. The Polyamide 6.6 moulded housing absorbs humidity from its surroundings. However, it does not crystallise water in the plastic itself as is the case in thermosetting plastic. The H₂O groups combine within the molecular structure.

Thus moulded plastic housing becomes fracture proof and unbreakable even in sub zero temperature conditions.

Polyamide 6.6 is difficult to ignite, self-extinguishing, burns only as long as there is a supporting flame and is rated V2 according to UL 94. It has excellent resistance to micro organisms, bacteria, enzymes and termites. Good ageing resistance and insensitivity to ultra violet light makes it suitable for tropical and open air applications. Polyamide 6.6 has excellent resistance to fuels, oils, fats and most common solvents like aliphatic and aromatic carbohydrates, ketons and alcohols.

Typical properties of insulation material

Property	Unit	Thermoset High Grade Melamine	Engineering Thermoplastic Polyamide 6.6
Specific Gravity	-	1.5	1.2 - 1.15
Upper Temperature Limit	°C	130	105
Lower Temperature Limit	°C	- 55	- 50
Volume Resistivity	Ohm cm	10 ¹¹	10 ¹²
Surface Resistivity	Ohm	10 ¹⁰	10 ¹⁰
Dielectric Strength	KV/cm	100	400
Tropical Resistance	-	Good	Good
Flammability	Grade	V0	V2 / V0 [#]
Flexibility	-	-	Excellent

V0 available on request

CE Marking

The CE marking is, in particular an indication that the products comply with the essential requirements of applicable directives and that the products have been subject to a conformity assessment procedure provided for in the directives. CE marking ensures free trading within Europe. elecDirect.com terminal blocks are CE marked and the products comply to Low Voltage Directive, 73/23/EEC,

At elecDirect.com the Product Development cycle, production & assembly of components and supply are all controlled by an ISO 9001:2000 Quality Management System.

elecDirect.com Products not only fulfill Customers needs and requirements of standards and specifications but also surpass the same.

