

# VOICE/DATA & LOW VOLTAGE

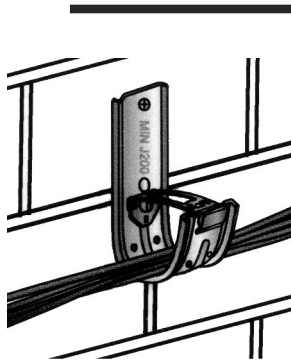

## CABLE SUPPORT J-HOOKS

- Cost effective alternative to expensive cable tray.
- Accommodates Category 5, fiber-optic, and interduct.
- Provides support without stress to sensitive voice/data cables.
- Continuous wide-base radius supports natural curve of cable eliminating kinking, bending, and crimping.
- Cable wire retainer is supplied with every part.

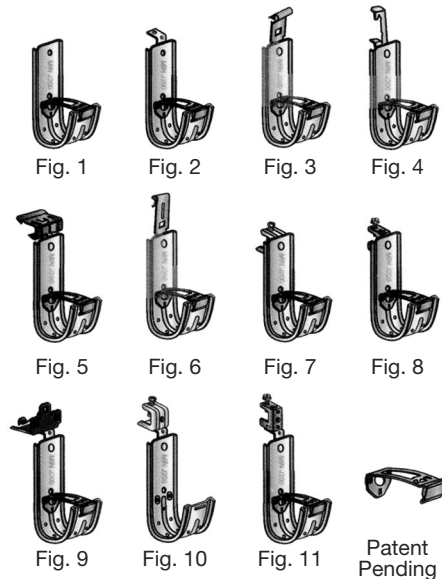

Part #	FIG	Description	Std. Pkg.
J200	1	2" J-Hook	50
J200B	2	2" J Hook W/Bracket	50
J200ABC25	3	Hammer on - 1/16"-1/4" angled Z Purlin	50
J200APS	4	Fits #12 wire through 1/4" rod and 1/8"-3/8" flange	50
J200SFC18	5	Hammer on - 1/8"-1/4" flange	50
J200SFC516	5	Hammer on - 5/16"-1/2" flange	50
J200SFC916	5	Hammer on - 9/16"-3/4" flange	50
J200VBC25	6	Hammer on - 1/16"-1/4" vertical flange	50
J200600	7	Screw on - up to 1/2" flange	50
J200500	8	Screw on - up to 1/2" flange	50
J200BBC18	9	Hammer on - 1/8"-1/4" flange	50
J200BBC516	9	Hammer on - 5/16"-1/2" flange	50
J200BBC916	9	Hammer on - 9/16"-3/4" flange	50
J200B600	10	Screw on - up to 1/2" flange	50
J200B500	11	Screw on - up to 1/2" flange	50

### Another solution for today's challenging installations!

The new 2" J-Hook cable support system, designed to be versatile, can be attached to a wide variety of structures using beam clamps, clips, and many other support components available from elecDirect.com. The wide-base support eliminates the undesirable impact of point-loads that can cause band-width deterioration and damage to category 5, fiber-optic, and other sensitive cables. This unique system is labour and time saving – another efficient method of installation!