

90030

MM	IN
1.77	0.070
9.65	0.380
11.17	0.440
16.00	0.630
27.63	1.088
28.44	1.120
50.29	1.980

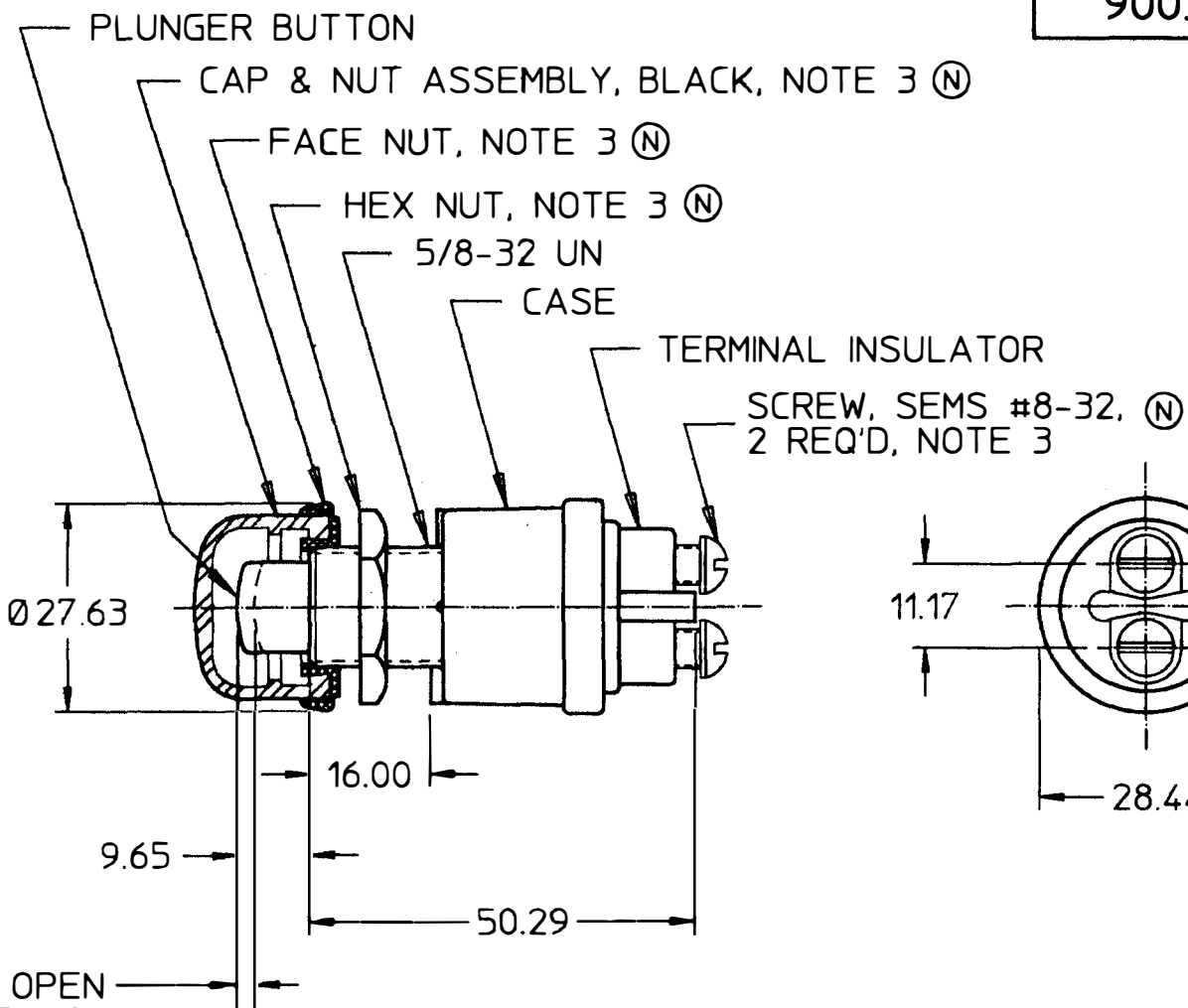

FRONT VIEW OF CASE

CONTACTS NORMALLY OPEN
 CLOSED WHEN PLUNGER IS
 DEPRESSED 1.770 APPROX.
 AND THRU REMAINDER OF
 TRAVEL

METRIC

35 AMPS	12 VDC
20 AMPS	24 VDC
CURRENT RATING	

- NOTES:
1. ALL STEEL PARTS PLATED
 2. SILVER CONTACT SURFACES (N)
 3. PARTS MAYBE ASSEMBLED OR SUPPLIED IN A BAG (P)

DO NOT SCALE

LET.	WAS	DATE	BY	LET.	WAS	DATE	BY	MATERIAL	DRAWN	CHK	APVD	SCALE	DATE DRAWN
									CF	JMP		1:1	11/9/67
								FINISH	Cole Hersee Co. 20 OLD COLONY AVENUE, BOSTON, MA. U.S.A. 02127				DATE BLUEPRINTED
				P	ECN #26813	7/17/97	AJS	TOLERANCES					SW, P-P, MOM, N.O.
				N	ECN #26688 PUT ON CAD	5/23/97	CHW	DECIMAL ± ANGLE ±					