

NOTES:

- ① MAT'L: COPPER (STOCK TKN. $\frac{.031}{.79}$ ^{±.001})
 PLATING: ELECTRO-TIN (.0003 MIN.)
- ② INSULATION: MOLDED PVC (BLUE)

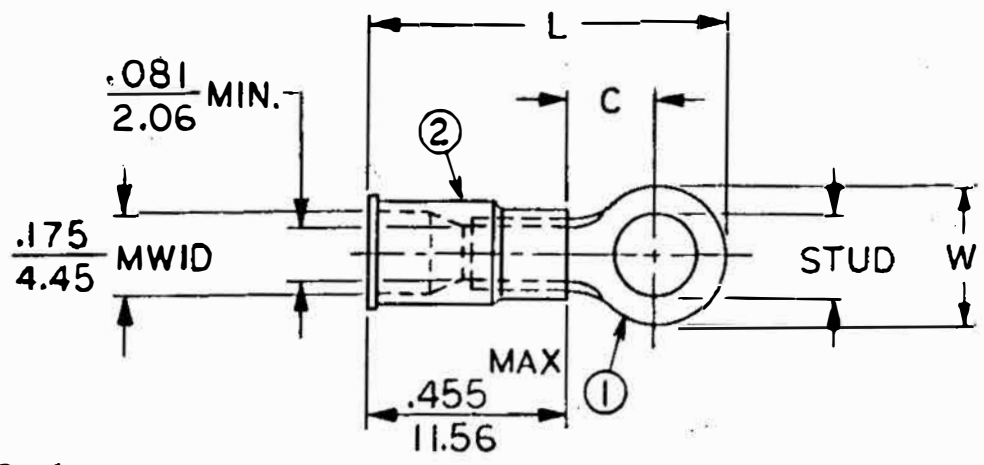

STUD SIZES: (±.005)

- 02 = .094
- 04 = .119
- 06 = .146
- 08 = .173
- 10 = .198
- 14 = .265
- 56 = .328
- 38 = .390

"UL" LISTING # E32244
 "CSA" LISTING # 18689

MWID = MAXIMUM WIRE INSULATION DIAMETER

WIRE SIZE: 16-14 AWG
 1.0-2.5 MM²

ALL DIMENSIONS = $\frac{\text{INCHES}}{\text{MM}}$

PART NUMBER	"W" ±.010	"C" MIN.	"L" MAX.	AVAILABLE STUD SIZES
	$\frac{.534}{13.56}$	$\frac{.554}{14.07}$	$\frac{1.311}{33.30}$	10X, 14X, 56X, 38X
R4B6S(M)	$\frac{.250}{6.35}$	$\frac{.209}{5.31}$	$\frac{.835}{21.21}$	02X, 04X, 06X, 08X
	$\frac{.467}{11.86}$	$\frac{.388}{9.86}$	$\frac{1.112}{28.24}$	10X, 14X, 56X
	$\frac{.312}{7.92}$	$\frac{.285}{7.24}$	$\frac{.926}{23.52}$	04X, 06X, 08X, 10X
	$\frac{.342}{8.69}$	$\frac{.310}{7.87}$	$\frac{.971}{24.66}$	04X, 06X, 08X, 10X

DIMENSIONAL TOLERANCES UNLESS OTHERWISE SPECIFIED			REFERENCE	SCALE: NTS	DATE	TITLE: RING TONGUE TERMINAL INSULKRIMP 200 SERIES
FRAC.	DEC.	ANG.		DRWN. BY: <i>yo</i>	10-25-84	
±	±	±		CHKD. BY: <i>GZ</i>	11-3-84	
				APPRD. BY:		
						DWG. NO. A CUSTOMER DWG.